

KLEMANTIS

INSTRUCTION MANUAL

KLEMANTIS AS1000 (AL2001)

KLEMANTIS AS500 (AL2002)

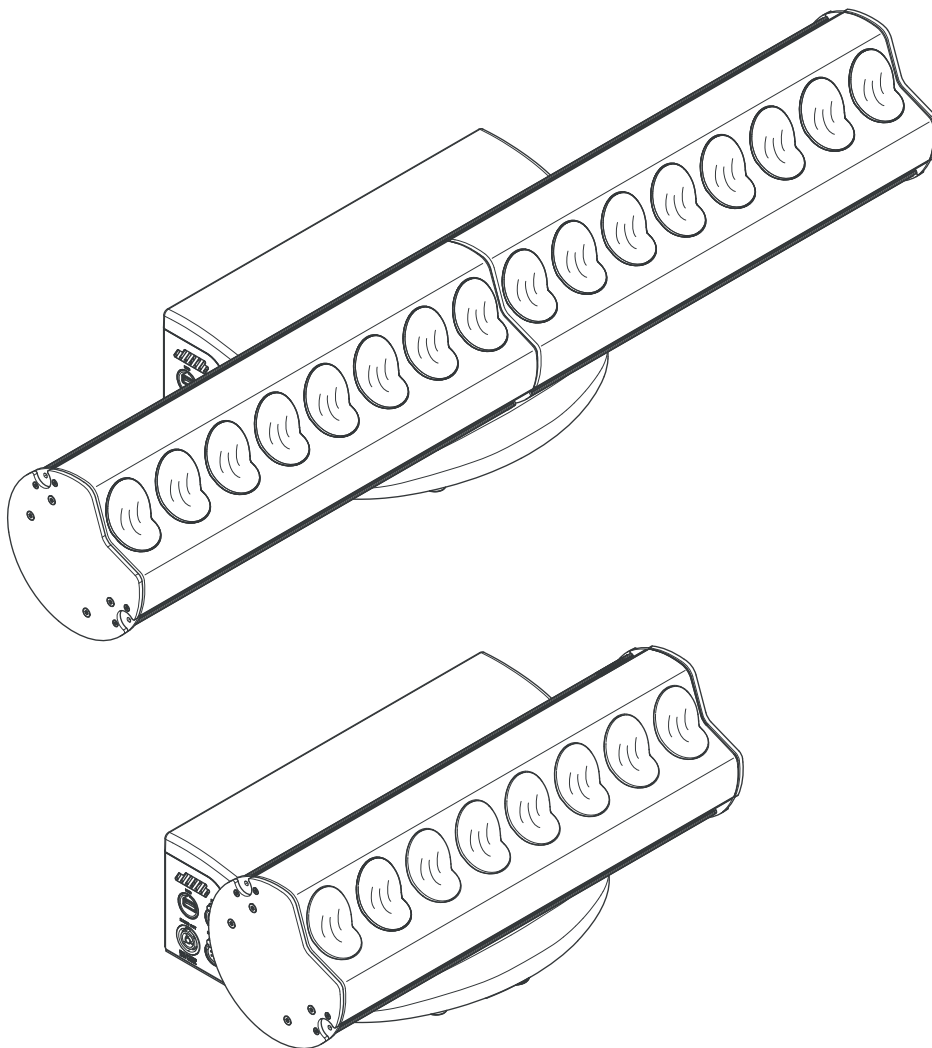

Congratulations on choosing an ADB product! We thank you for your custom.

Please note that this fixture - like all the others in the wide ADB range - has been designed and made with total quality assurance to ensure excellent performance and best meet your expectations and requirements.

INDEX

- 1. SAFETY INFORMATION**
- 2. INTRODUCTION**
 - 2.1 Presentation
 - 2.2 Main features and control options
 - 2.3 Product overview
- 3. UNPACKING**
 - 3.1 Package contents
 - 3.2 Accessories
- 4. INSTALLATION AND START-UP**
 - 4.1 Installing the fixture
 - 4.1.1 Introduction
 - 4.1.2 Installation configurations
 - 4.1.3 How to calculate positioning distance from cyclorama
 - 4.1.4 Focus and tilt angle
 - 4.1.5 Tips&tricks
 - 4.2 Connecting to main Supply
 - 4.3 Connecting the control signal line: DMX / Art-Net
 - 4.4 Control Panel
- 5. MAINTENANCE**
 - 5.1 Fuses replacing
 - 5.2 Periodic cleaning
- 6. TECH DATA**
- 7. APPENDIX**
 - 7.1 The Klemantis installation procedure

1. SAFETY INFORMATION

EN How to get a multilingual version of your SAFETY INSTRUCTIONS.
You may always download multilingual safety instruction for this ADB product from:
<https://www.adbstagelight.com/downloads>
Ref: FIS01B - KLEMANTIS AS Safety Information

IT Come ottenere le INFORMAZIONI DI SICUREZZA nella versione multilingue.
Puoi sempre scaricare la versione multilingue delle Informazioni di Sicurezza per questo prodotto ADB al seguente link:
<https://www.adbstagelight.com/downloads>
Ref: FIS01B - KLEMANTIS AS Safety Information

DE So erhalten Sie Ihr INFORMATIONEN ZUR SICHERHEIT in der mehrsprachigen Version.
Sie können die mehrsprachige Version des Handbuchs mit Sicherheitshinweisen für dieses ADB Produkt unter folgendem Link herunterladen:
<https://www.adbstagelight.com/downloads>
Ref: FIS01B - KLEMANTIS AS Safety Information

ES Cómo obtener tu INFORMACIONES DE SEGURIDAD en la versión multilingüe.
Siempre puedes descargar la versión multilingüe del Manual de Instrucciones de Seguridad para este producto ADB en el siguiente enlace.
<https://www.adbstagelight.com/downloads>
Ref: FIS01B - KLEMANTIS AS Safety Information

FR Comment obtenir votre CONSIGNES DE SÉCURITÉ dans la version multilingue.
Vous pouvez toujours télécharger la version multilingue du Manuel d'Instructions de Sécurité pour ce produit ADB au lien suivant :
<https://www.adbstagelight.com/downloads>
Ref: FIS01B - KLEMANTIS AS Safety Information

RU Где достать ИНСТРУКЦИЮ ПО ТЕХНИКЕ БЕЗОПАСНОСТИ на нескольких языках.
Вы всегда можете скачать многоязычную инструкцию по технике безопасности для данного изделия ADB по ссылке:
www.adbstagelight.com/downloads
Ref: FIS01B - KLEMANTIS AS Safety Information

2. INTRODUCTION

2.1 Presentation

The new ADB KLEMANTIS is an asymmetric cyclight based on a six-colour LED module, which uses cutting-edge HCR LED technology to deliver a wide selection of colours from bold hues to pastel shades.

Thanks to an innovative algorithm, the unit is capable of achieving a stable CRI of up to 99, as well as an impressive tunable white light ranging from 2500K to 8000K.

Its light output is enhanced with an innovative optical unit, which enables the Klemantis to generate a uniform light with excellent diffusion and perfectly blended colours.

The KLEMANTIS is available in two models, both designed to work in a linear array. The KLEMANTIS AS1000 is one metre long and fitted with 16 multi-source LED modules. The KLEMANTIS AS500 is half a metre long and features 8 LEDs. They can be used horizontally, vertically, laid on the floor, or hung from above on a bar. The AS500 is particularly suitable for lighting cyclorama corners.

Unlike any other light on the market, the KLEMANTIS can be installed very close to the cyclorama (as little as 60 cm away) without the light distribution becoming uneven.

The Klemantis is a creative tool designed to meet today's lighting design needs. Its unique features and design reinvent the cyclorama concept, making it the perfect choice for any professional use.

An optional lens kit allows you to turn your asymmetrical optical unit into a symmetrical, fixed beam angle unit.

2.2 Main features and control options

The Klemantis has several control modes which make managing the six-colour LED module easy. The user can choose the option that best suits their programming preferences ranging from a simple three-channel RGB/CMY/HSL colour control mode, which gets the most from all six LED colours through a sophisticated algorithm, to direct control over each colour source through six 16 bit dedicated DMX channels.

The way the Klemantis behaves can be tailored to any specific application by setting its dimming curve, adjusting its frequency rate and correcting its tint. The unit ensures high colour stability and accuracy, fixture to fixture colour repeatability, and colour consistency over time.

Some of the main features and options include:

- Beam type: asymmetric flood
- Tunable white ranging from 2500K to 8000K, with perfect CCT
- Tungsten mode, to emulate the behaviour of a tungsten lamp during dimming from 0 to 100% and vice versa, including colour temperature adjustment
- Tint correction: +/- green/magenta adjustments
- 16-bit ultra-smooth dimming, with four different dimming curves available
- Smooth colour transition through different time, cross-fade and path options, and a gamma correction system
- Colour control: hue saturation luminosity (HSL), CMY, RGB (14 DMX ch. footprint) and RAW (27 DMX ch. footprint) modes fully exploit the potential of the six-colour system
- Wide selection of digital filters (colour macros) which reproduce the spectrum of gel filters with tungsten bulbs
- High colour stability and accuracy, even in tungsten mode, thanks to a high resolution driver
- Colour consistency over time and temperature changes, thanks to combined fixture calibration and an LED ageing compensation algorithm
- Fixture to fixture colour repeatability, thanks to tight wavelength binning selection and 100% fixture calibration
- Flicker-free, thanks to PWM frequency adjustment from 1 KHz to 50 KHz (10 Hz steps)

2.3 Product overview

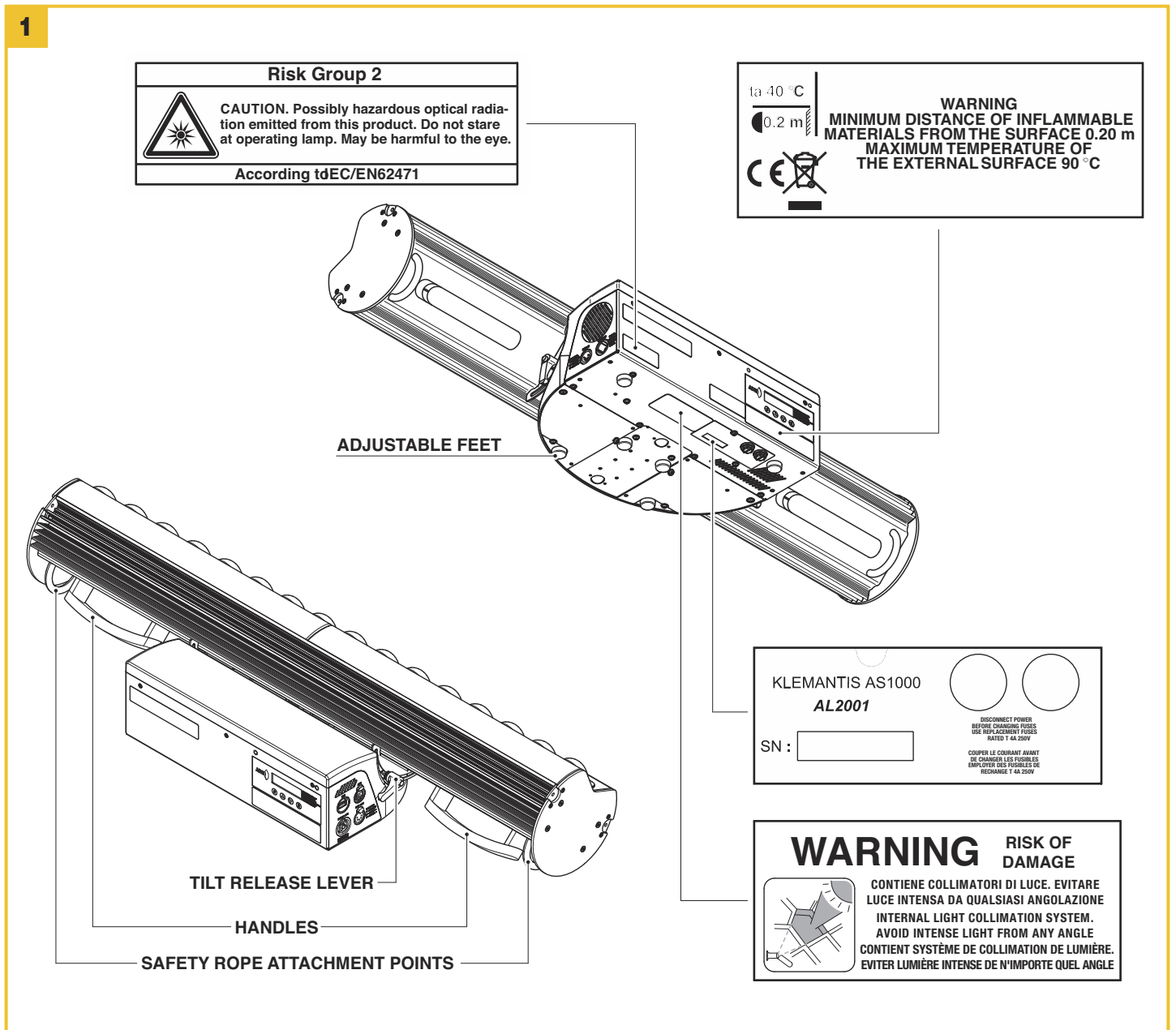

Fig. 1
Klemantis AS1000 components

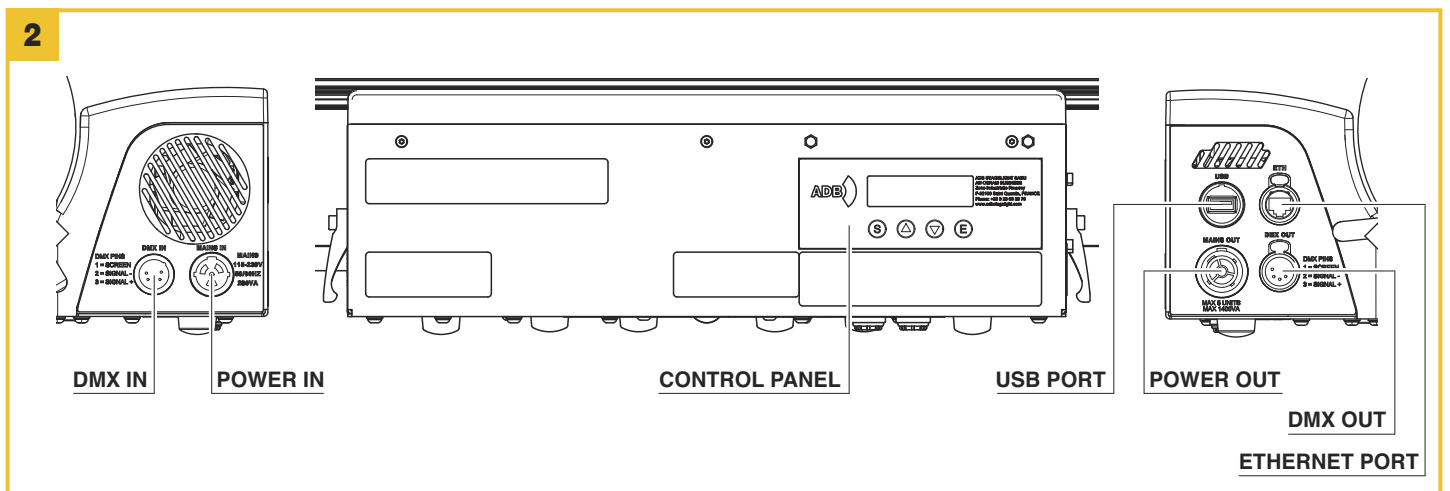
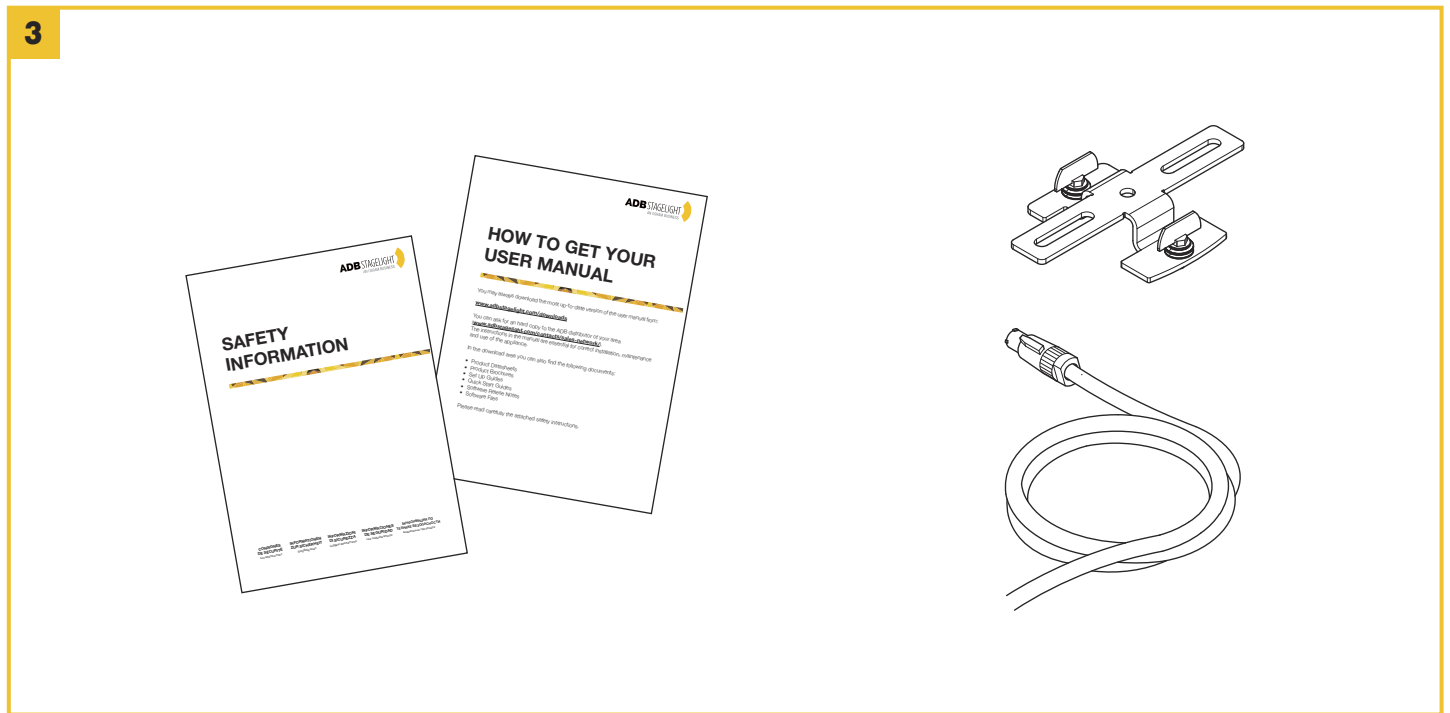

Fig. 2
Rear panel

3. UNPACKING

3.1 Package contents



Package contents - Fig. 3

- 1x Safety Information Leaflet FIS01B
- 1x Omega Bracket 319102-801
- 1x powerCON TRUE 1 to Bare Ends Mains Cable CAB02B-801

3.2 Optional Accessories

- 4** AZ2001000200 Lenses 28°
AZ2001000210 Lenses 40°

A

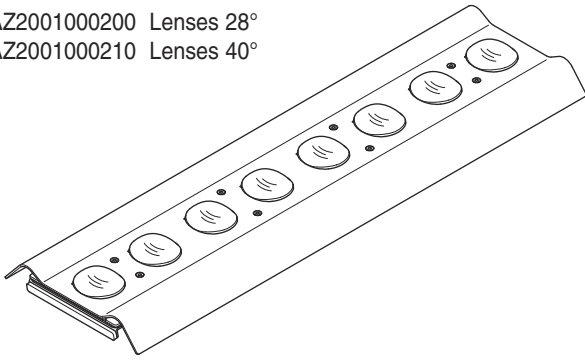

B

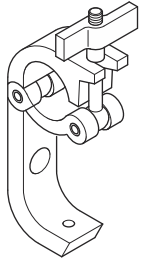

C

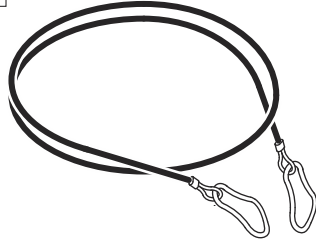

D

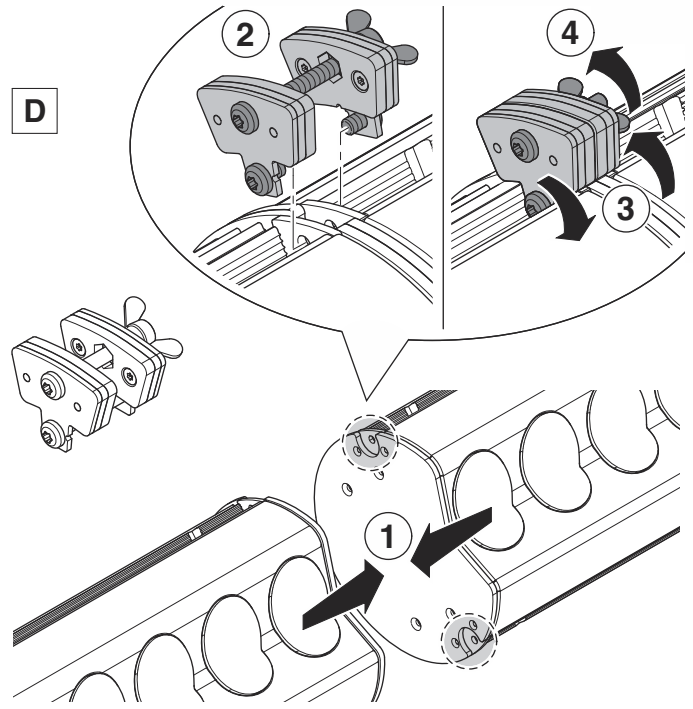

E

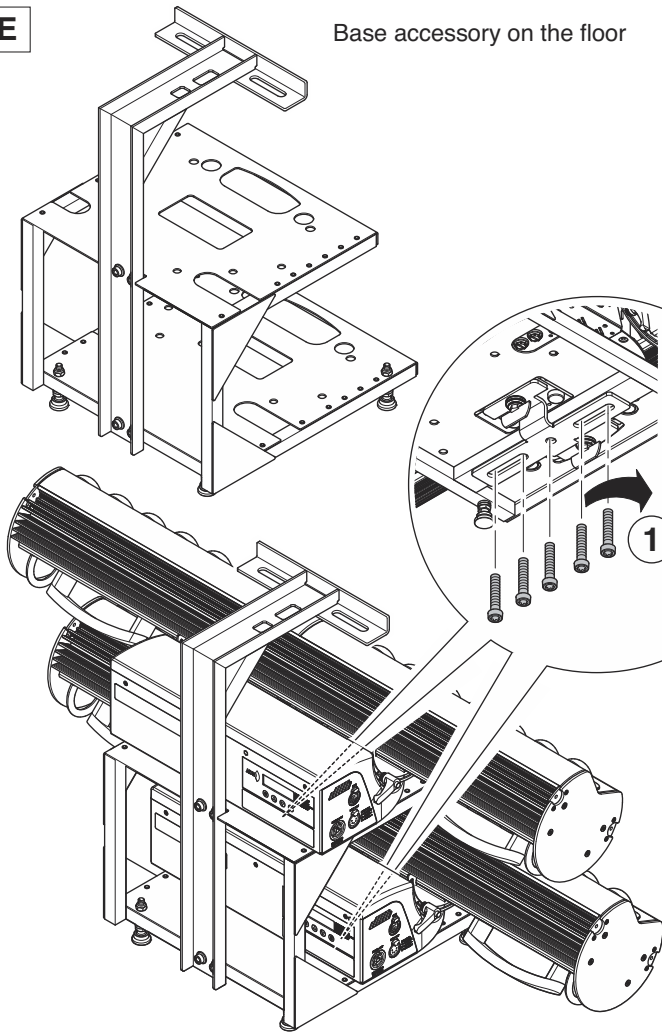

Base accessory on the floor

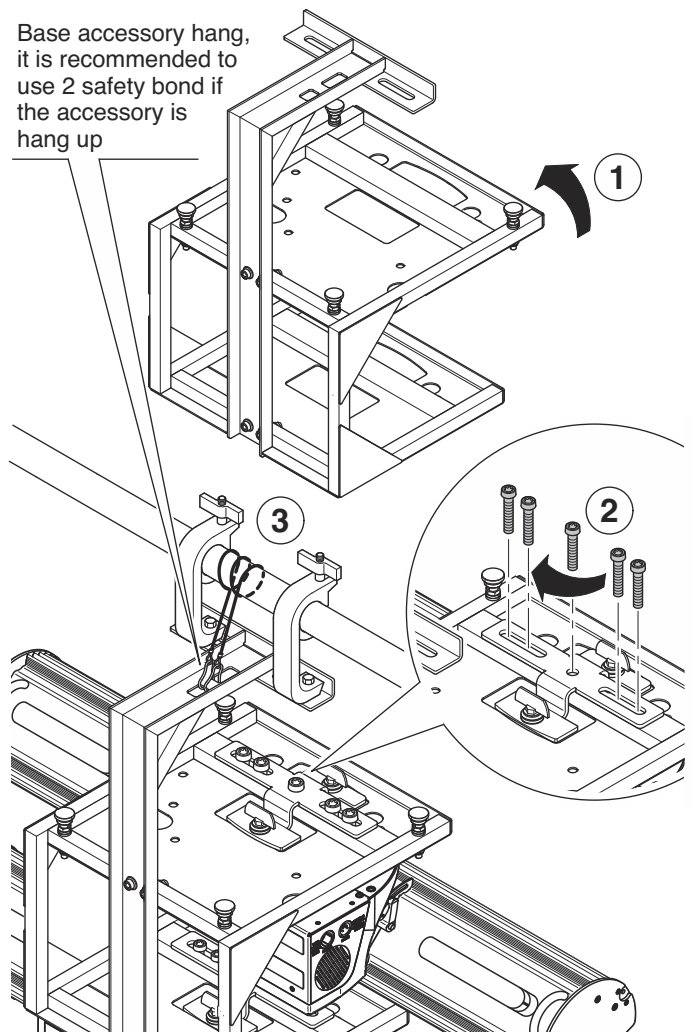

Base accessory hang,
it is recommended to
use 2 safety bond if
the accessory is
hang up

Fig. 4

A - AZ2001000200 Kit Klemantis Symmetric Lenses 28° (2 sets of 0.5 meter)
AZ2001000210 Kit Klemantis Symmetric Lenses 40° (2 sets of 0.5 meter)
(provided in a box where both symmetrical and asymmetrical lenses can be stored)

B - Hook clamp - ADB-1092.10.600

C - Safety bond - 105041/001

D - Junction pin - AA20000001020

E - Base accessory to mount 2 Klemantis - AR2001000000

4. INSTALLATION AND START-UP

4.1 Installing the fixture

4.1.1 Introduction

The Klemantis' unique asymmetric optical unit has been designed to respond to the increasing need to illuminate walls, scenery and cycloramas uniformly with a smooth, even wash of seamlessly blended colours. The Klemantis ensures good colour consistency and uniform light distribution on very high scenery, even when the lighting fixture and the projection surface are very close together.

One of the key aspects of the Klemantis is its special precise light intensity distribution. It should therefore be installed carefully in order to exploit its potential and optimize its performance in cyclorama illumination.

4.1.2 Installation configurations

The Klemantis has been designed to work in a linear set-up, so the fixtures must be aligned in a continuous row. The maximum clearance allowed between one fixture and the next is 20 mm.

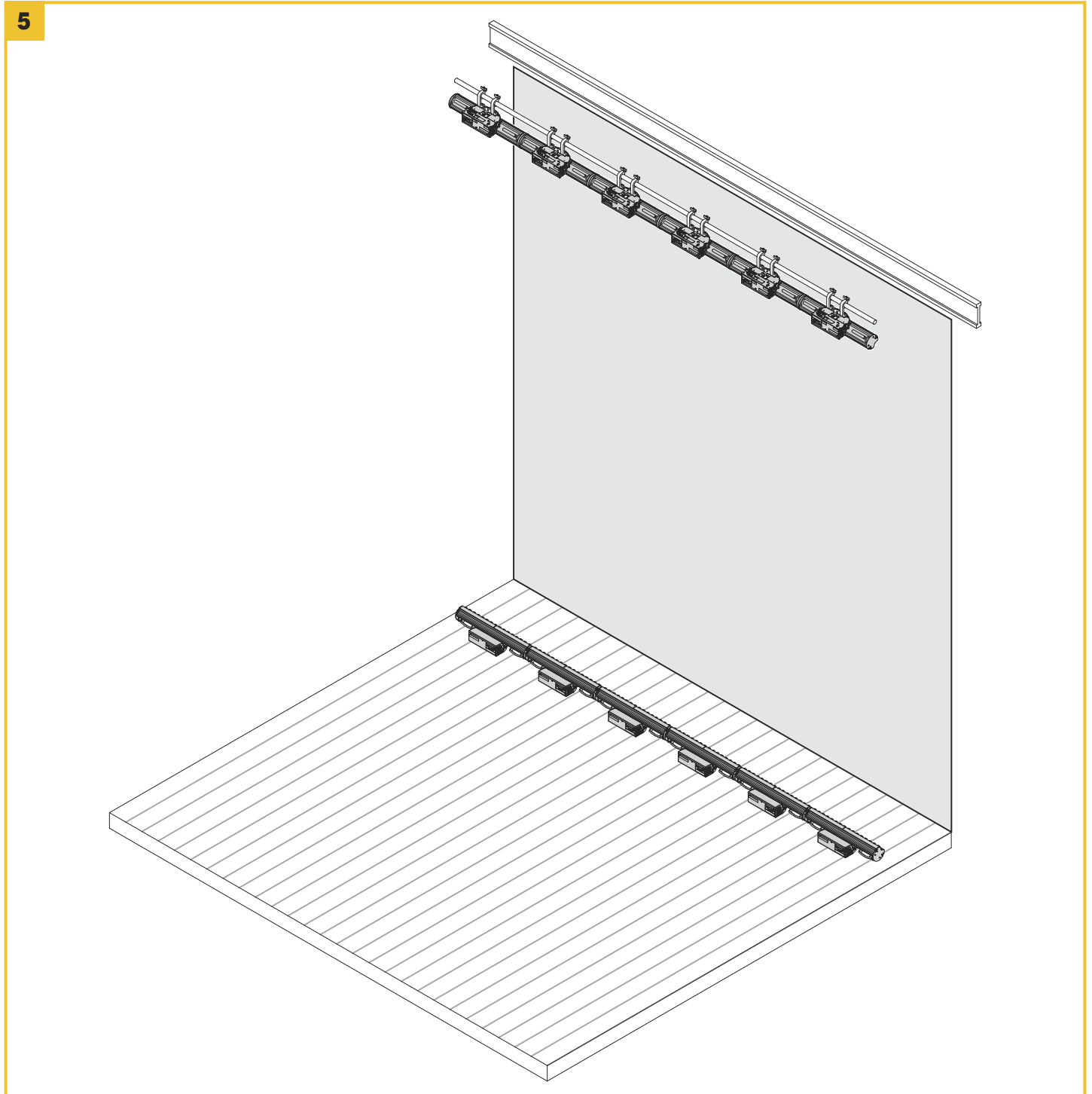

Klemantis installation Fig. 5
Top and bottom configuration

Klemantis units may be installed in a bottom, top and bottom, or top only set-up, depending on the height of the surface to be lit and on the required effect (total evenness of the light on the cyclorama or a linearly fading intensity effect).

When Klemantis units are installed in a single row (top or bottom), they create a uniform horizontal light distribution which fades vertically (see Fig. 1). When they are installed on the floor and on the ceiling (top and bottom rows) at the same distance from the cyclorama, they create an outstandingly uniform vertical light distribution (see Fig. 2). Top and bottom set-up is ideal in order to achieve the most even light distribution on the cyclorama.

6

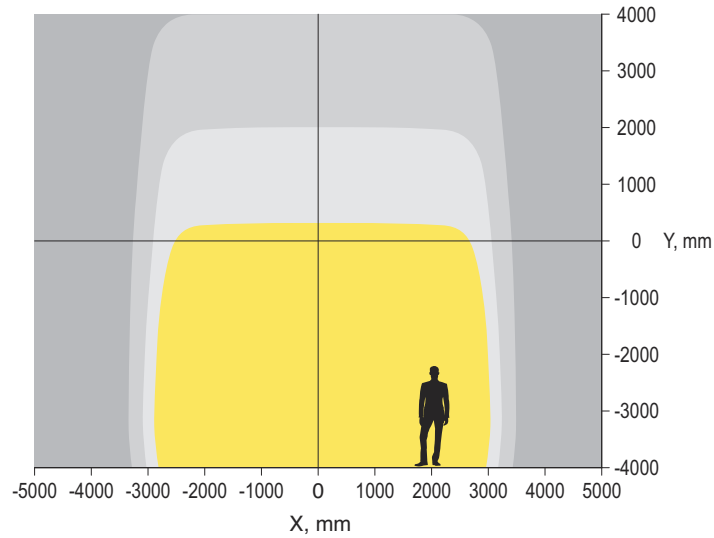

Figure 1
single row setup

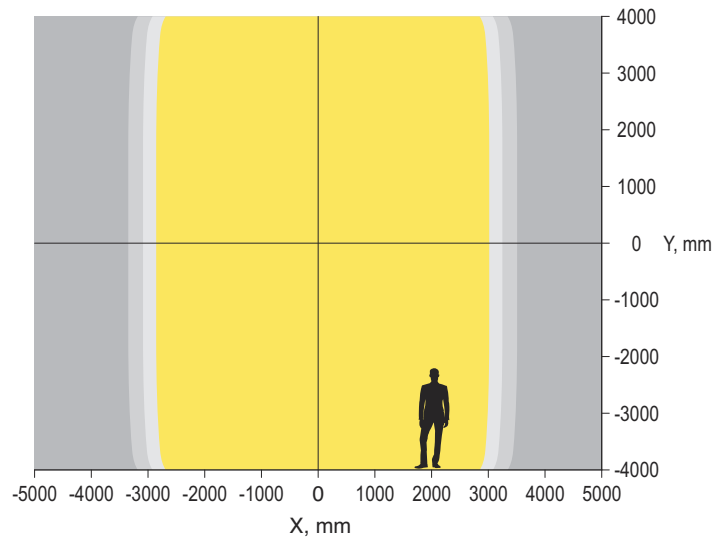
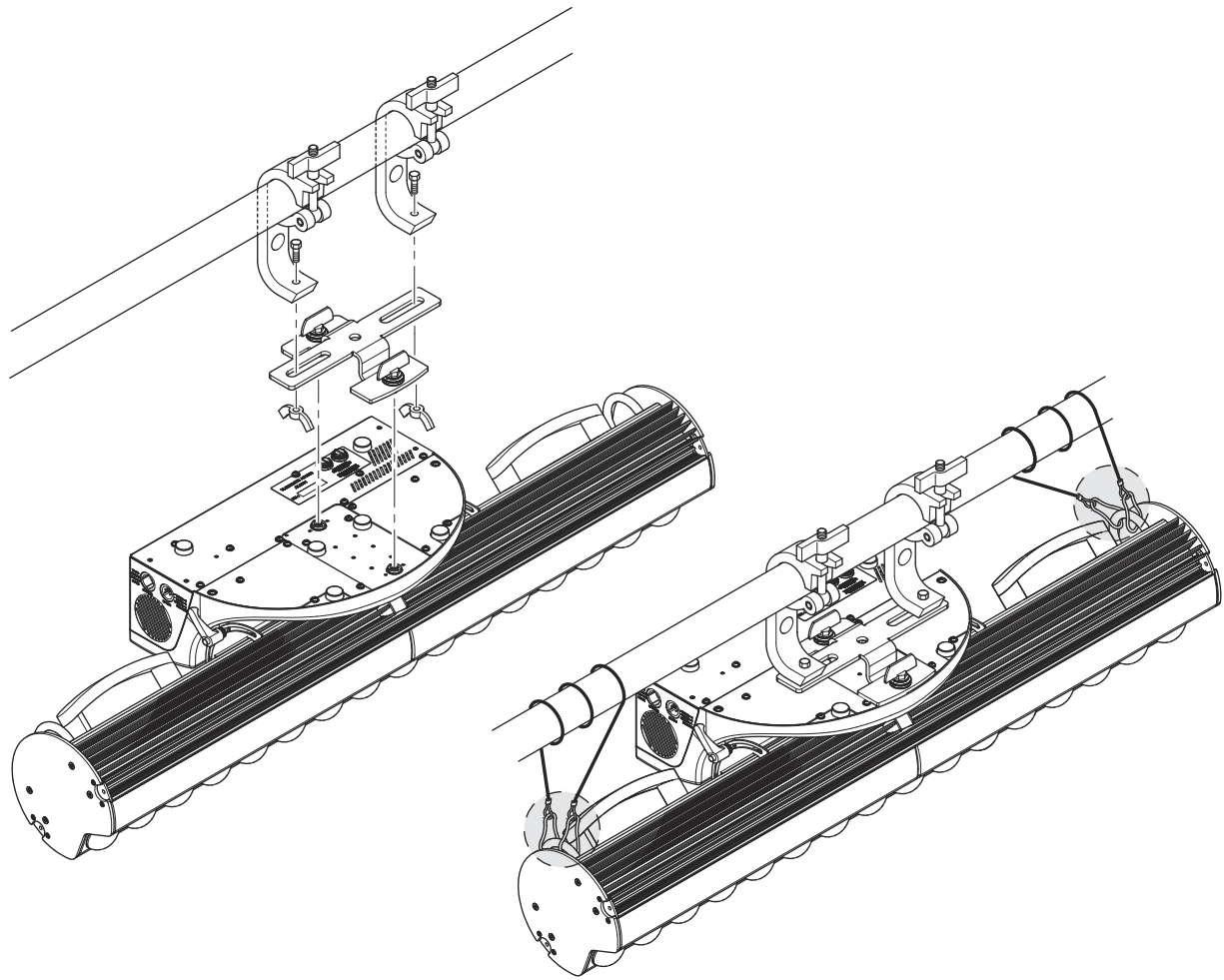
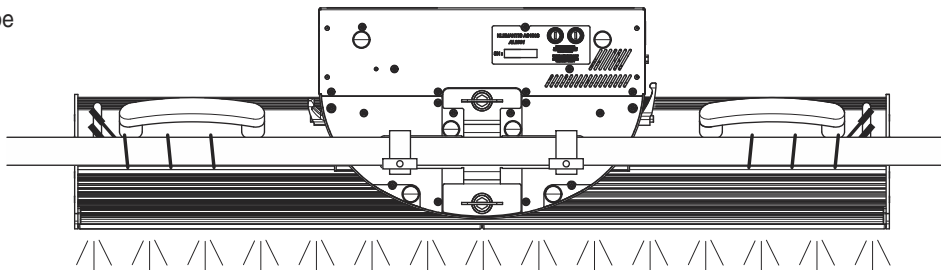

Figure 2
top and bottom row setup

Fig. 6
Klemantis' performance with different installation configurations



Safety cables must be inserted in the two anchor points and attached to the truss



Installing the fixture - Fig. 7

The fixture can be installed on the floor, on a truss, on the ceiling or on a wall.

WARNING: safety cables must be installed in every case except when the fixture is on the ground. (Code 2X 105041/001 available on request.)
The safety cables must be fastened to the unit supporting structure and then hooked onto the fastening points found on the sides of the fixture.



WARNING: light collimation system

This unit contains an internal light collimation system.
 Avoid intense light from any angle.

4.1.3 How to calculate the installation distance from a cyclorama

In the case of the two-row set-up, the recommended distance for the most even light on a cyclorama can be easily calculated using the following formula:

$$d = \frac{H}{8}$$

d = distance from cyclorama

H = height of cyclorama

8

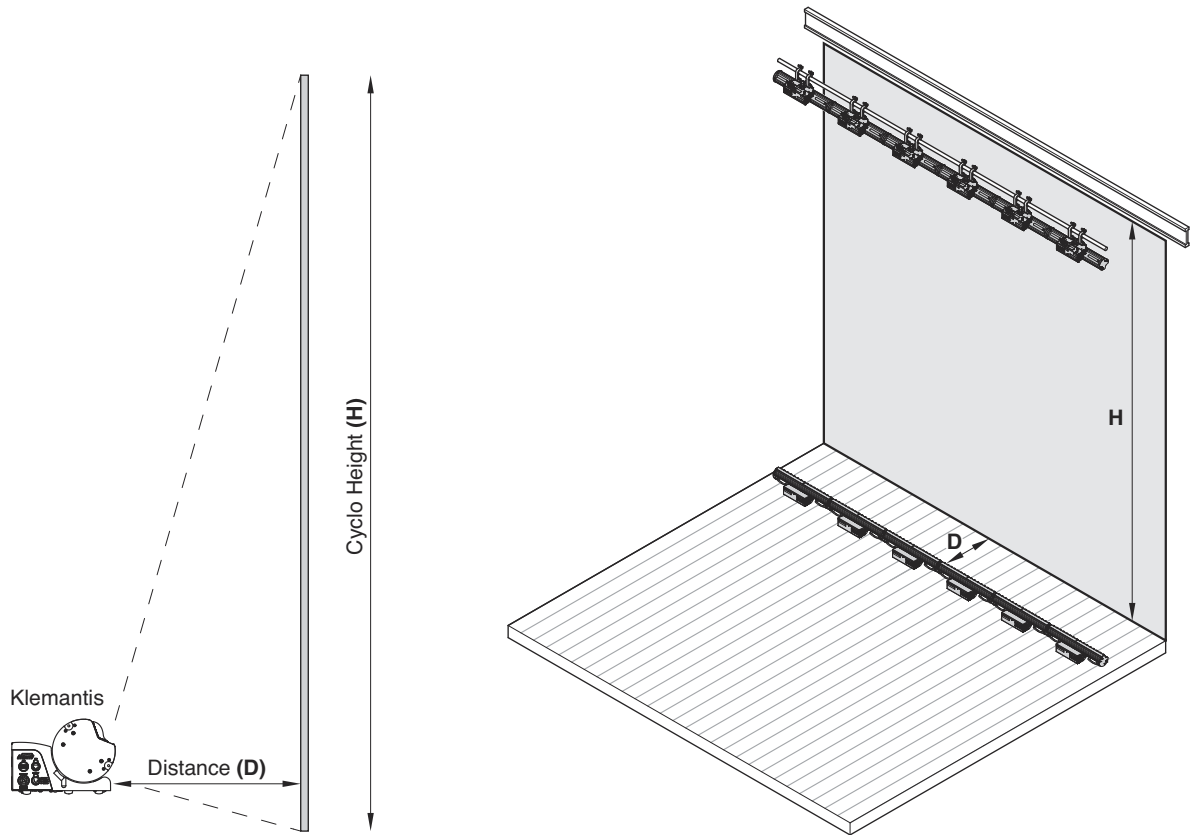

4.1.4 Focus and tilt angle

The Klemantis performs best if tilted 45°

When one Klemantis is installed properly in place (at the correct distance, perfectly parallel to the wall and tilted 45°), the light distribution on the cyclorama looks like a rectangular distribution with soft edges on the sides and soft vertical fading.

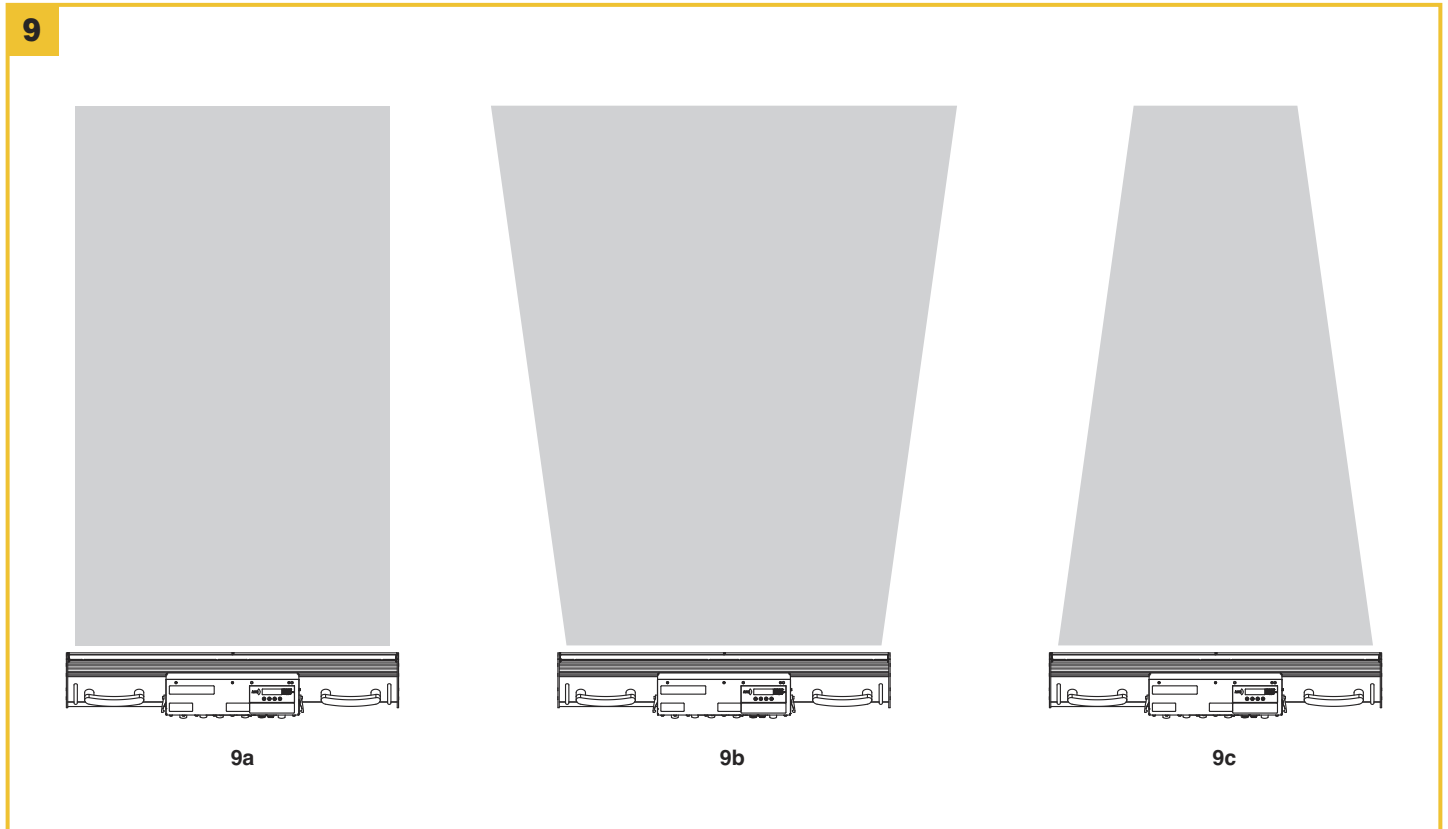

Focus Fig. 9

9a: correct - 9b, 9c: wrong

If the lighted area has a trapezoidal shape, correct the tilt angle until the projection sides become straight and parallel (fig. 9a)

Summary of check points for correct installation

- Make sure the Klemantis is aligned parallel to the wall
- Check the unit tilt angle (45° is the recommended angle for best performance)
- Check the distance between the fixture and the projection surface $d = \frac{H}{8}$ (see point 4.1.3 of the User Manual for detailed instructions)

4.1.5 Tips & Tricks

The biggest issues which occur in case of improper installation are:

- Gaps or peaks, which appear in the vertical light half way up the cyclorama.
 - Tilting effect: if tilted upwards, the generated target light-rectangle becomes a trapezium with major base on the bottom. If tilted downwards, the generated target light-rectangle becomes a trapezium with major base on the bottom → adjust the Klemantis's tilting
- Narrow vertical gaps in light (10 - 30 cm), which appear on the cyclorama from either floor or ceiling Klemantis units.
 - Clearance effect: there might be too large a clearance between two adjacent Klemantis units → reduce this clearance by installing the units closer together.
- Uneven horizontal light distribution (>1 m), which appears on the cyclorama from either floor or top Klemantis units.
 - The Klemantis units are not parallel to the cyclorama → re-arrange the units along a straight line which is parallel to the cyclorama.
- Vertical colour transition does not change horizontally in two-row installation, when floor and ceiling rows are set to two different colours.
 - Tilting effect: if the Klemantis units on the same row are not tilted properly and equally, the light intensity varies on the cyclorama → adjust Klemantis tilting.

Should you require further instructions about installation, see Appendix: Klemantis Installation Steps.

4.2 Connecting to main power supply

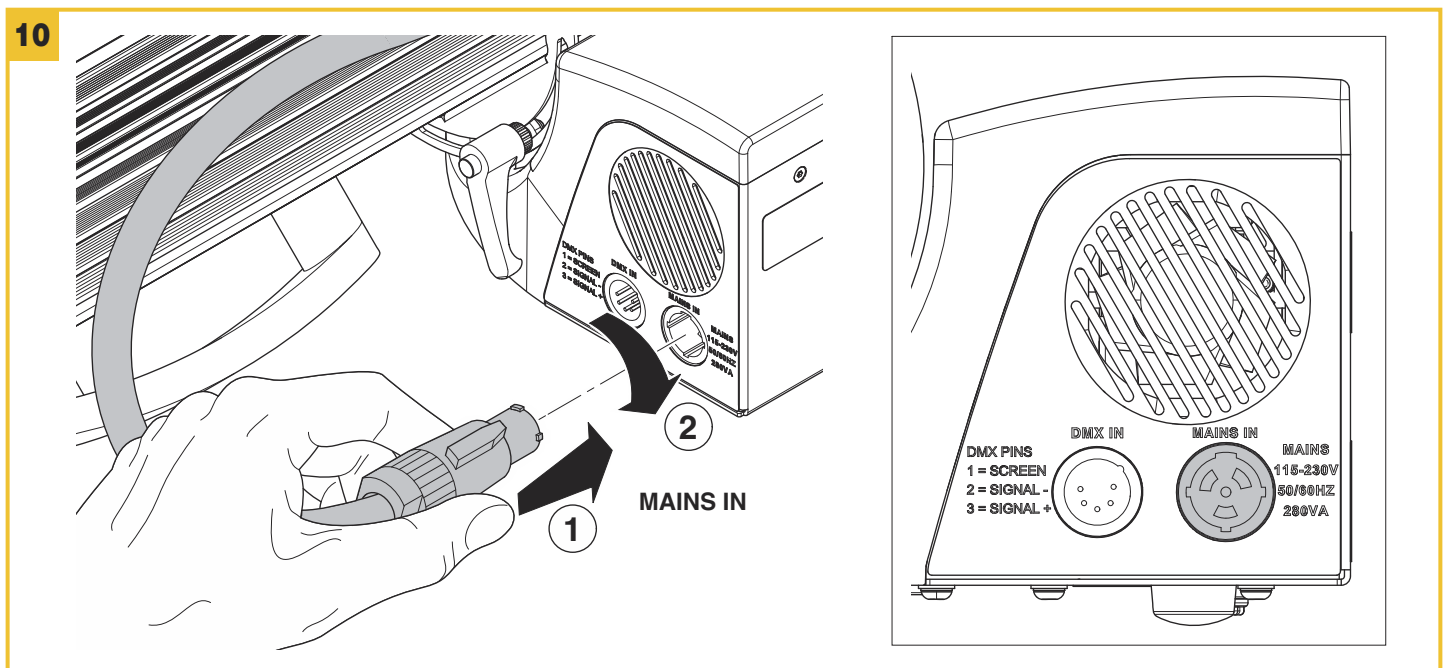

Attach the power cable to the Power In connector - Fig. 10

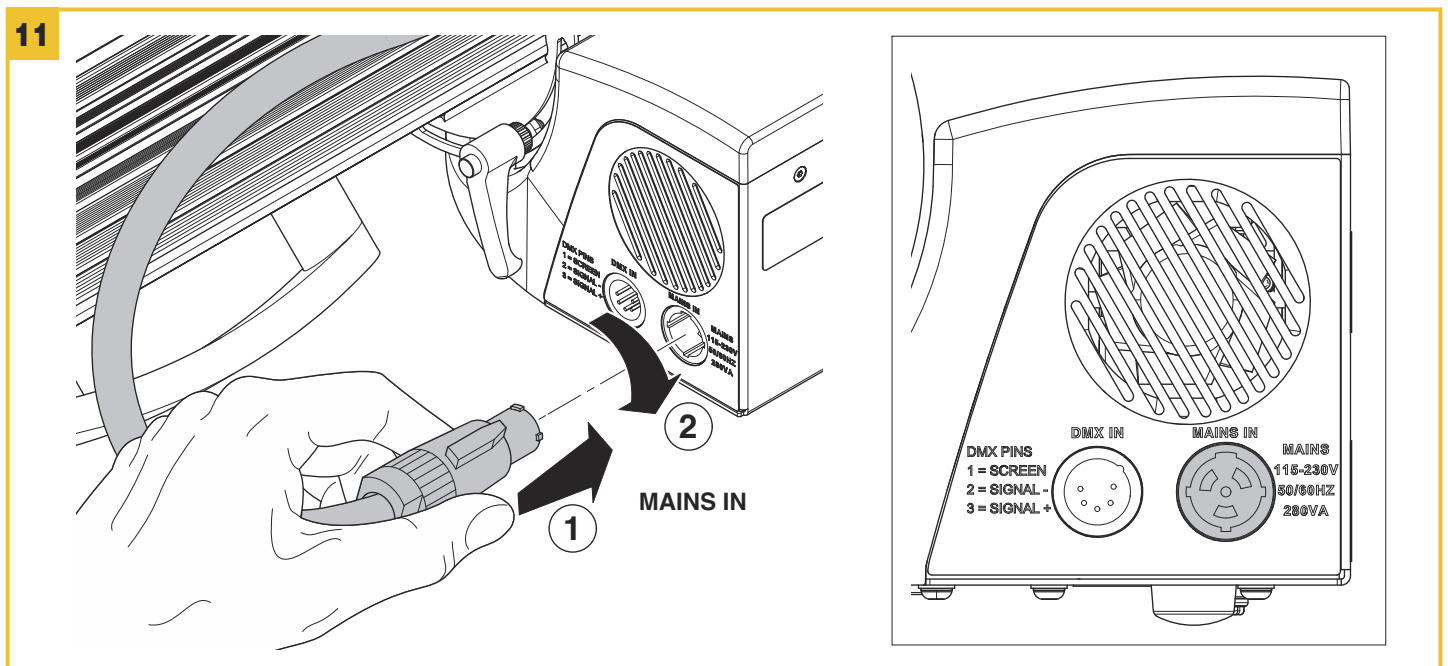

Link additional fixtures via the Power Thru connector - Fig. 11

Up to five Klemantis AS1000s (or eight Klemantis AS500s) may be linked via Power Thru connectors on the same power line (16 Amp).

NOTE: plug the cable into AC power 100/240V 50/60Hz on a non-dimmable circuit. **Do not connect to a dimmer power line.**

4.3 Connecting the control signal line: DMX / Art-Net

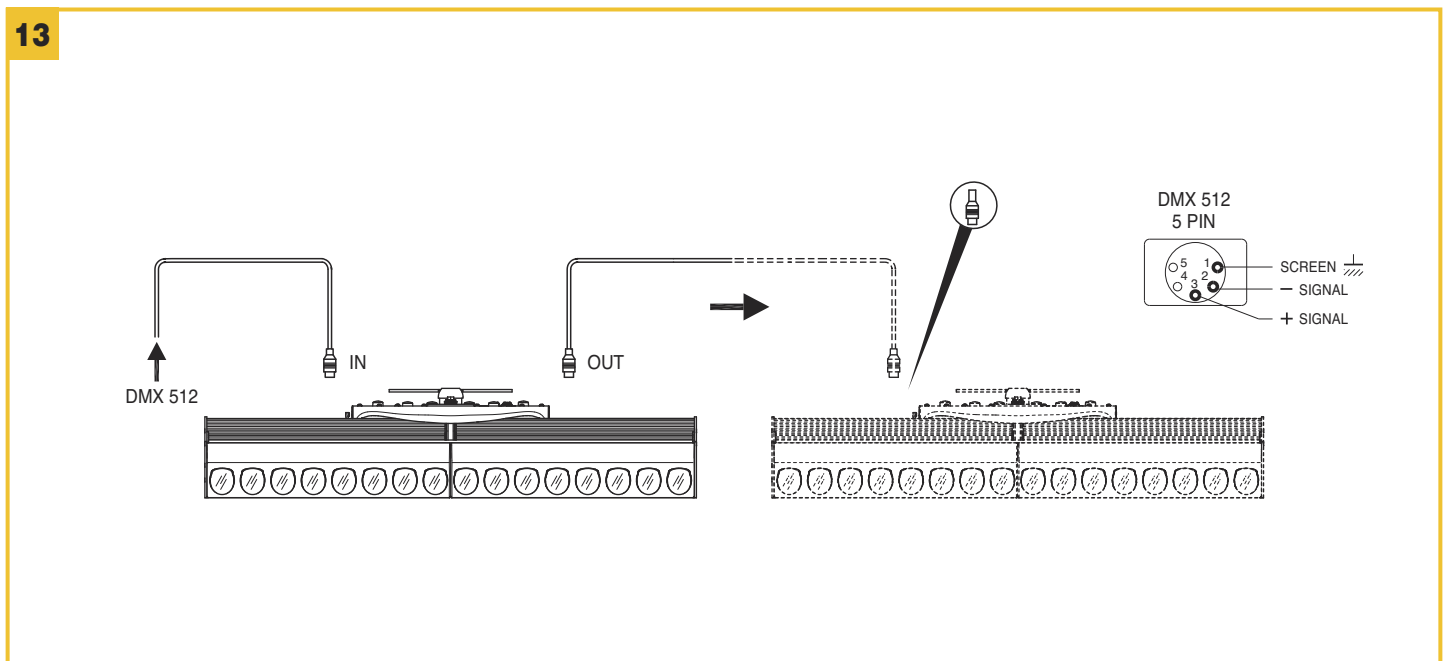
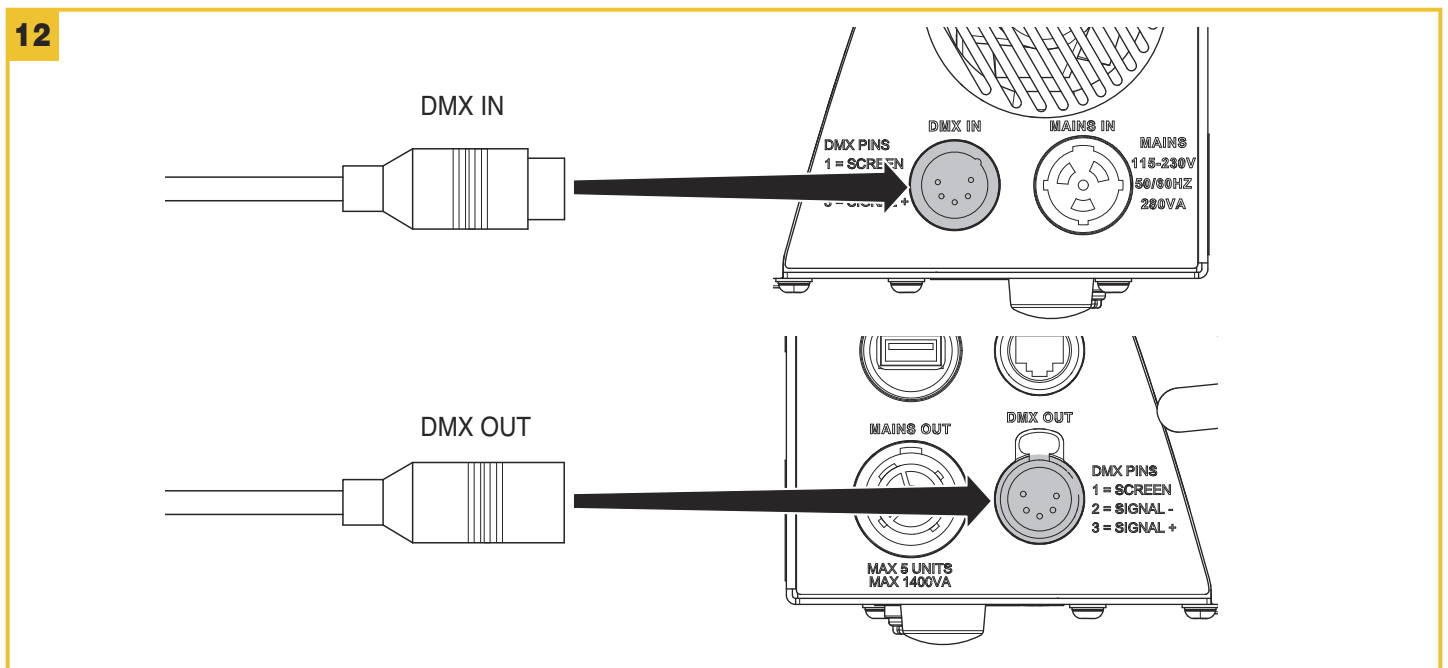

Connecting the control signal line: DMX / Art-Net - Fig. 12-13

Use a cable conforming to specifications EIA RS-485: 2-pole twisted, shielded, 120Ω characteristic impedance, 22-24 AWG, low capacity. Do not use microphone cable or other cable with characteristics differing from those specified.

Use XLR type 5-pin male/female connectors for end connections. A terminating plug with a resistance of 120 (minimum 1/4 W) between terminals 2 and 3 must be inserted on the last unit.

IMPORTANT: Avoid contact between wires and with the metal casing of the connector. The casing must be connected to the shield braid and pin 1.

4.4 Control panel

14

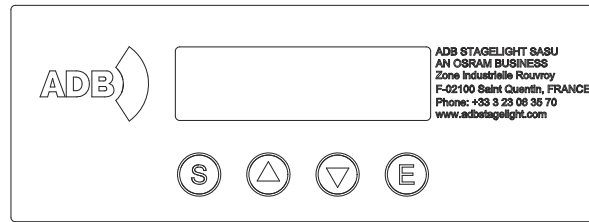





Switching the fixture on - Fig. 14

The fixture comes on immediately when the power cord is plugged in.

Menu settings status

If no button is pressed, the display automatically returns to idle status after a time-out interval of about 60 seconds. Any modified value that has not yet been confirmed with the (E) key will be cancelled.

Button functions – Menu SET → product overview → front panel

SELECT 	<ul style="list-style-type: none"> • If pressed in idle status: Cyclically switches between idle status and menu settings. • If pressed while setting a menu: Moves to an upper level without changing anything (exits the function)
DOWN 	Decreases the value displayed (with auto-repetition), or passes to the next item on the menu For quick access to the minimum parameter value, press the UP key while holding down the DOWN key.
UP 	Increases the value displayed (with auto-repetition), or passes to the previous item on the menu For quick access to the maximum parameter value, press the DOWN key while holding down the UP key.
ENTER 	Confirms the displayed value, activates the displayed function or opens the next menu.

15

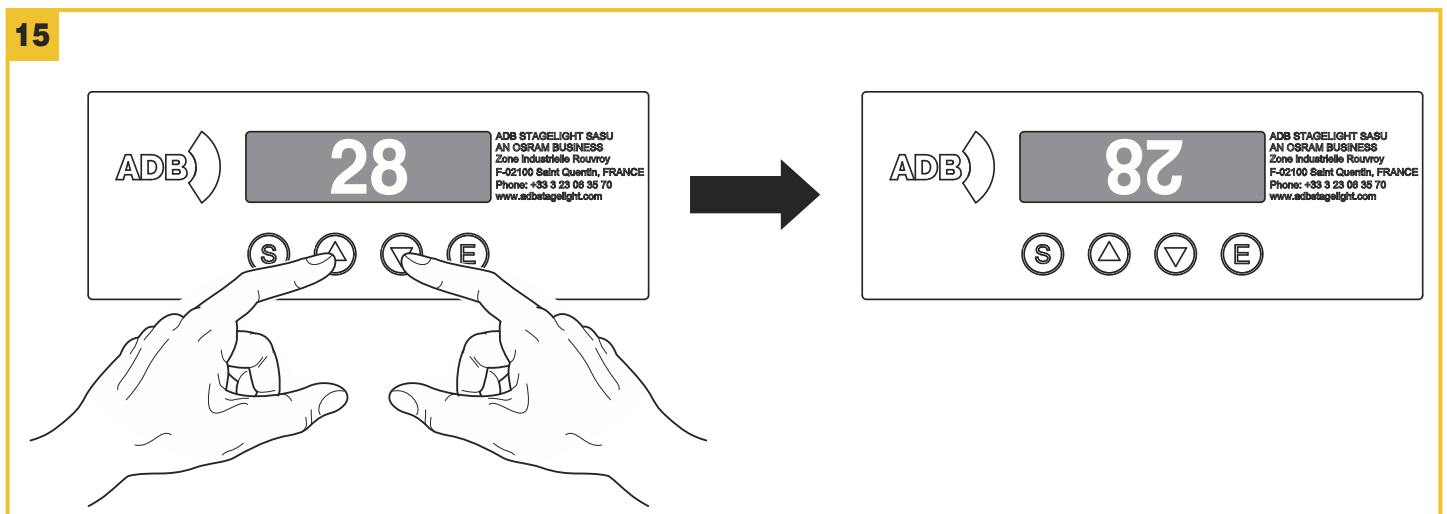

Display inversion - Fig. 14

To activate this function press the UP (▲) and DOWN (▼) keys at the same time while the display is in standby.

The condition is memorized and saved for subsequent switching too. To return to the initial state, repeat the operation again.

5. MAINTENANCE

5.1 Replacing fuses

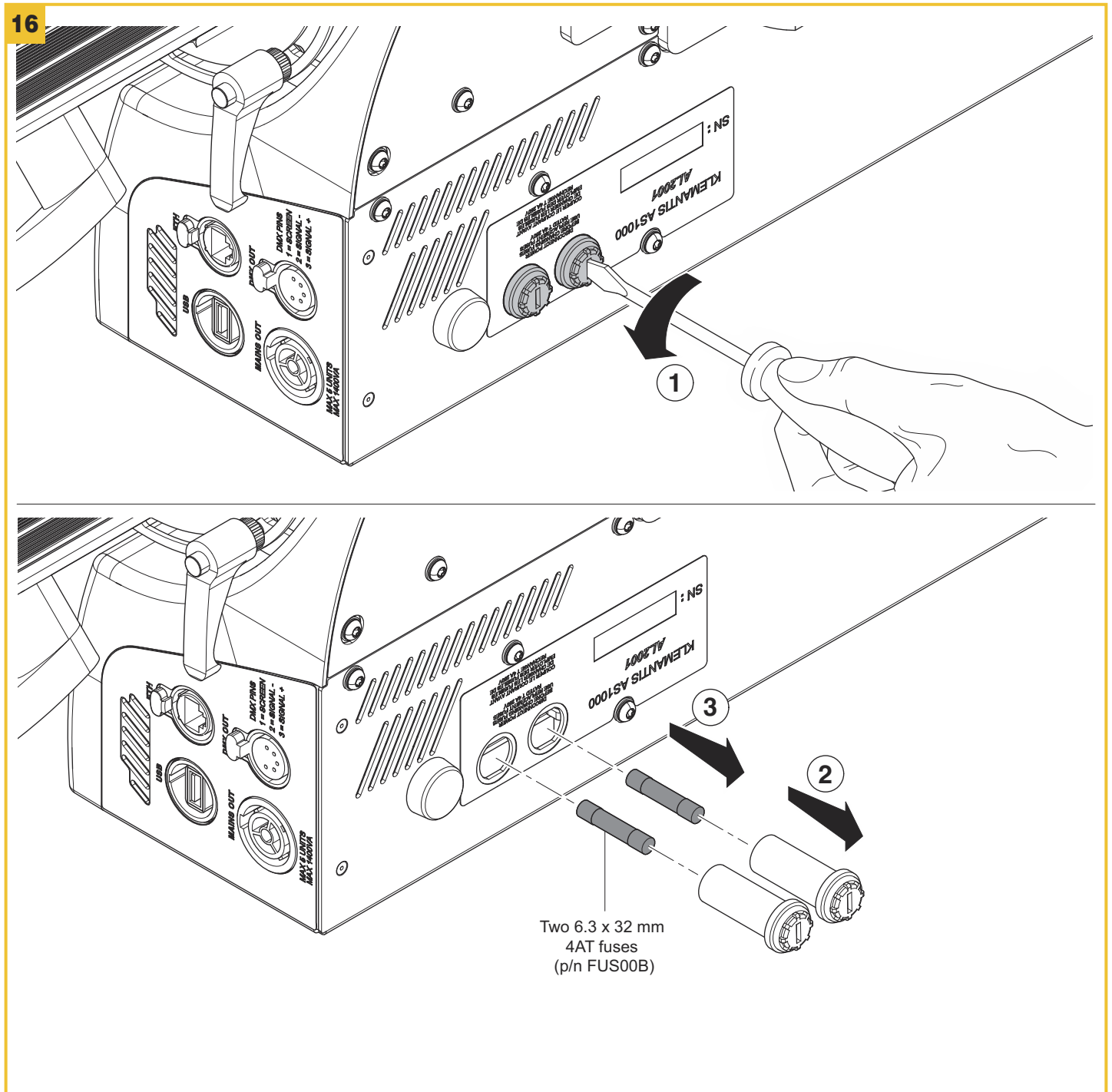

Replacing fuses - Fig. 16

Each fixture has two fuses on the main power cord connection.

5.2 Routine cleaning

17

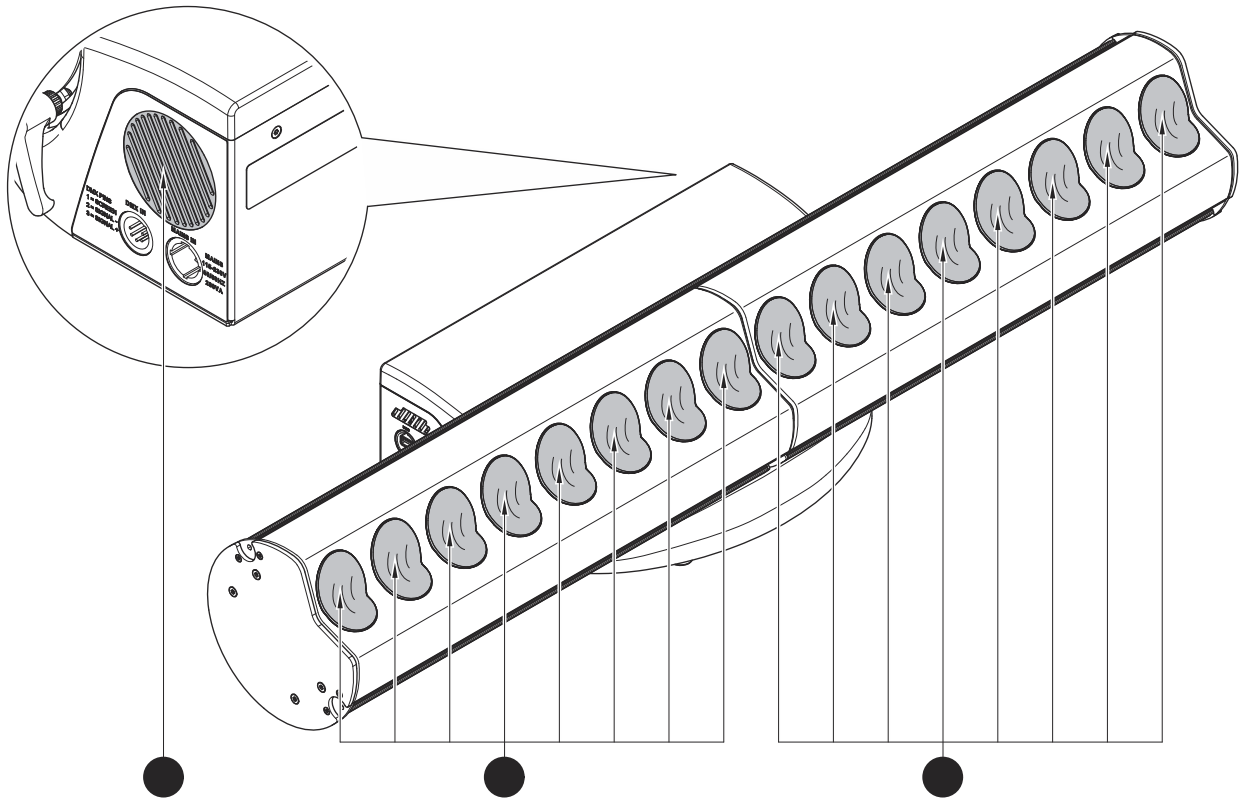

● Parts requiring frequent cleaning.

Routine cleaning - Fig. 17

To ensure optimal operation and performance for a long time it is essential to clean the parts subject to dust and grease deposits periodically. The frequency with which the following operations need to be carried out depends on various factors such as wear and the working environment (air humidity, dust, salinity, etc.).

We recommend that the fixture undergoes annual servicing by a qualified technician for special maintenance involving at least the following operations:

- General cleaning of internal parts.
- General visual check of internal parts, cabling, mechanical parts, etc.
- Electrical, photometric and functional checks; any necessary repairs.

IMPORTANT: Do not use compressed air at more than four atmospheres to clean the inside of the fixture (LED board area).

Clean the lenses using water and neutral soap only. Then dry thoroughly with a soft, non-abrasive cloth. (CAUTION: the use of alcohol or other detergents could damage the lenses).

6. TECH DATA

KLEMANTIS AS1000 - AS500

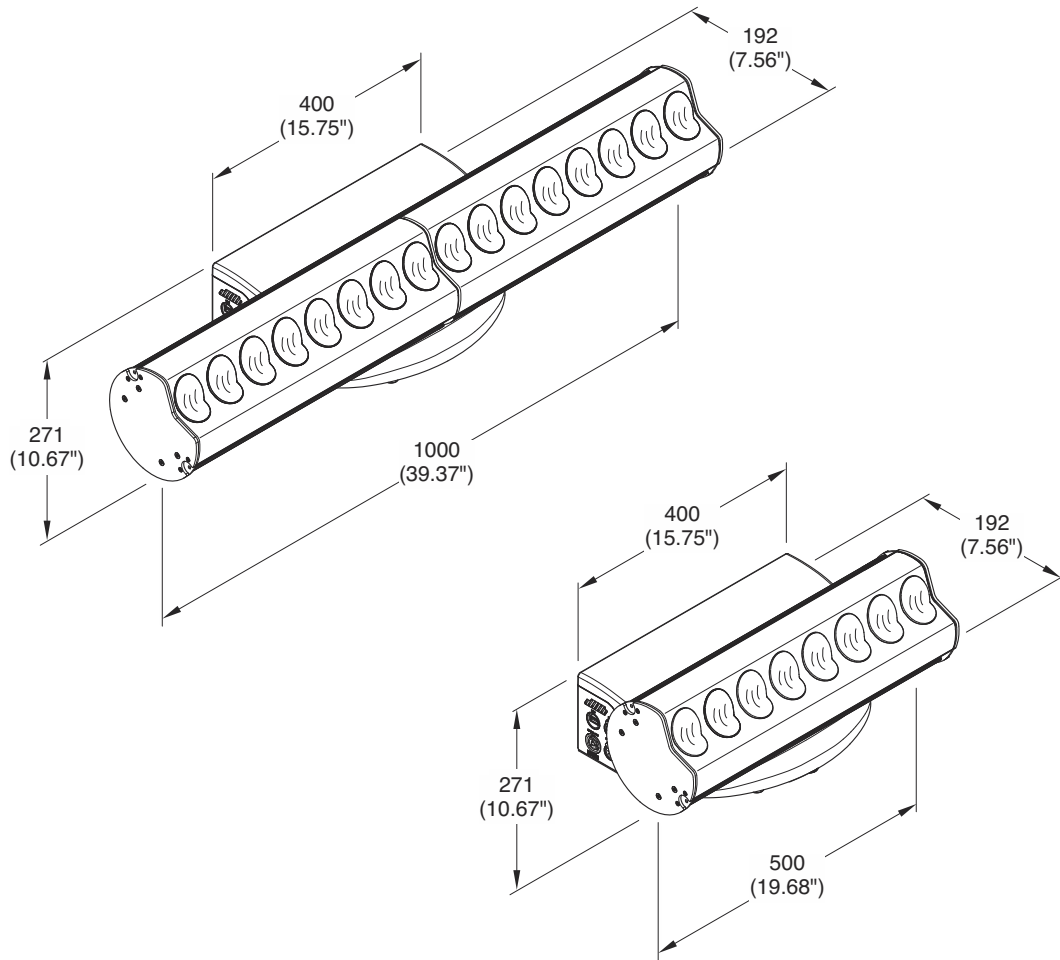

ELECTRICAL SPECS

- Power supply: electronic auto-ranging
- Input voltage range: 110-240Vac 50/60 Hz
- Max power consumption: 280 VA at 230V/50Hz (AS1000)
- Max power consumption: 170 VA at 230V/50Hz (AS500)

POWER CONNECTION

- Power input: Neutrik PowerCON TRUE 1
- Power thru: Neutrik PowerCON TRUE 1 (daisy chain up to 5 x Klemantis AS1000)

DATA CONNECTION

- Control protocols: DMX512 / RDM / Art-Net 4 / RDM over Art-Net 4
- Wireless control: available
- Data IN connector: 5 pins XLR + RJ45
- Data OUT connector: 5 pins XLR

MECHANICAL SPECS

- Painting: black with epoxidic powder
- Body: extruded aluminium and steel sheet
- Cooling system: automatic fan with variable speed/ LED cooling by natural convection
- Max noise level: 24.5 dB(A) @ 1m
- IP protection rate: IP20

WEIGHT

Klemantis AS500: 11 kg
Klemantis AS1000: 16 kg

OPERATIONAL SPECS

- Working position: 45° std, rot. +/-45°
- Min. distance to illuminated surface: 0.2m
- Ambient temp. (min-max): -20°C / +40° C
- Maximum surface temperature: 90°

OPTICAL SPECS

- Source: 8/16 HCR Exclusive LED module featuring six colors: Red + Green + Blue + Cyan + Amber + Lime
- Lifetime L₇₀: 57,000 h
- Color temperature: Tunable white ranging from 2500K to 8000K, with perfect CCT
- CRI >97 throughout the entire CCT (up to 99)
- Optics: FFL Asymmetric, proprietary optical design
- Horizontal spread: 49°
- Vertical spread: 108°

APPROVALS

- CE / ETL

PROVIDED WITH

- Neutrik PowerCON TRUE 1 power cable/bare ends (1.5m cable PVC insulated 3X1.5mm)
- Omega bracket

7. APPENDIX

7.1 Klemantis installation steps

The following steps summarize the recommended procedure for installing a single row of units (for instance on the floor):

1. Calculate the proper installation distance (D) from the cyclorama.
2. Place the Klemantis stably and make sure all Klemantis units are parallel to the cyclorama, at the set distance (D). Reduce the gap between two adjacent fixtures to a minimum (1 - 2 mm).
3. If the floor is not level, use the adjustable feet (**fig. 18**)

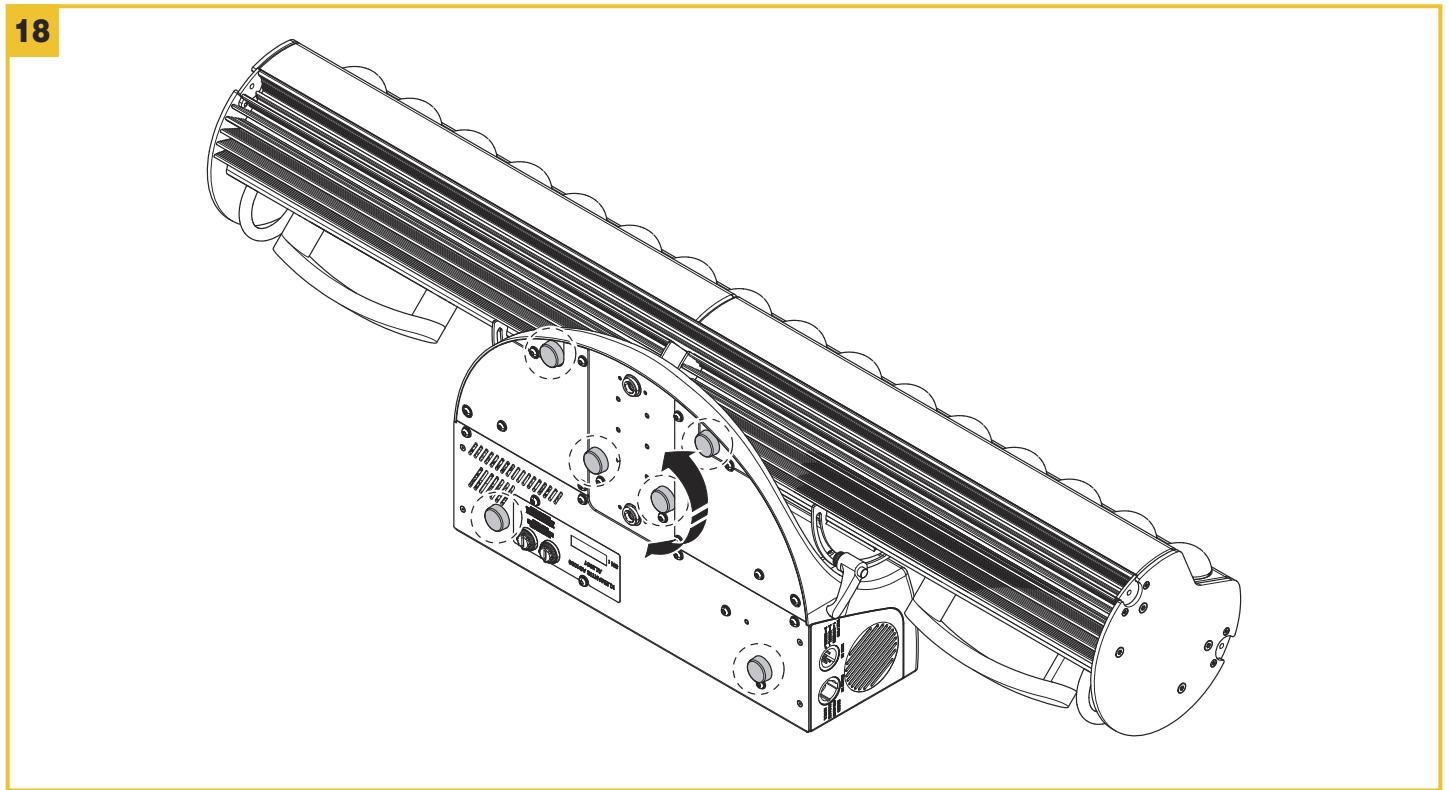

4. Adjust the tilt of each unit (a digital bubble level smartphone app may be used):
 - a. Before tightening the clamps, set all the Klemantis units to 0° in the back-stage-to-front-stage direction (**fig. 19**).

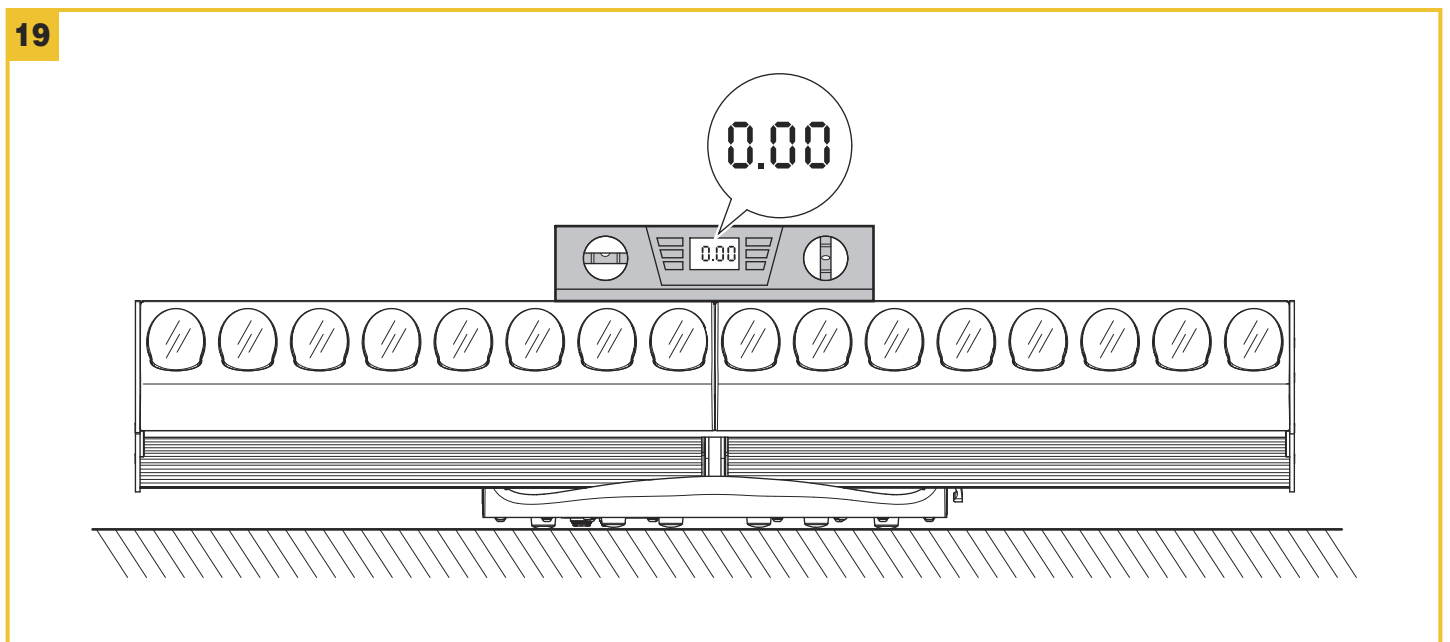

b. Loosen the tilting knobs so that the Klemantis units may be tilted (**fig. 20**).

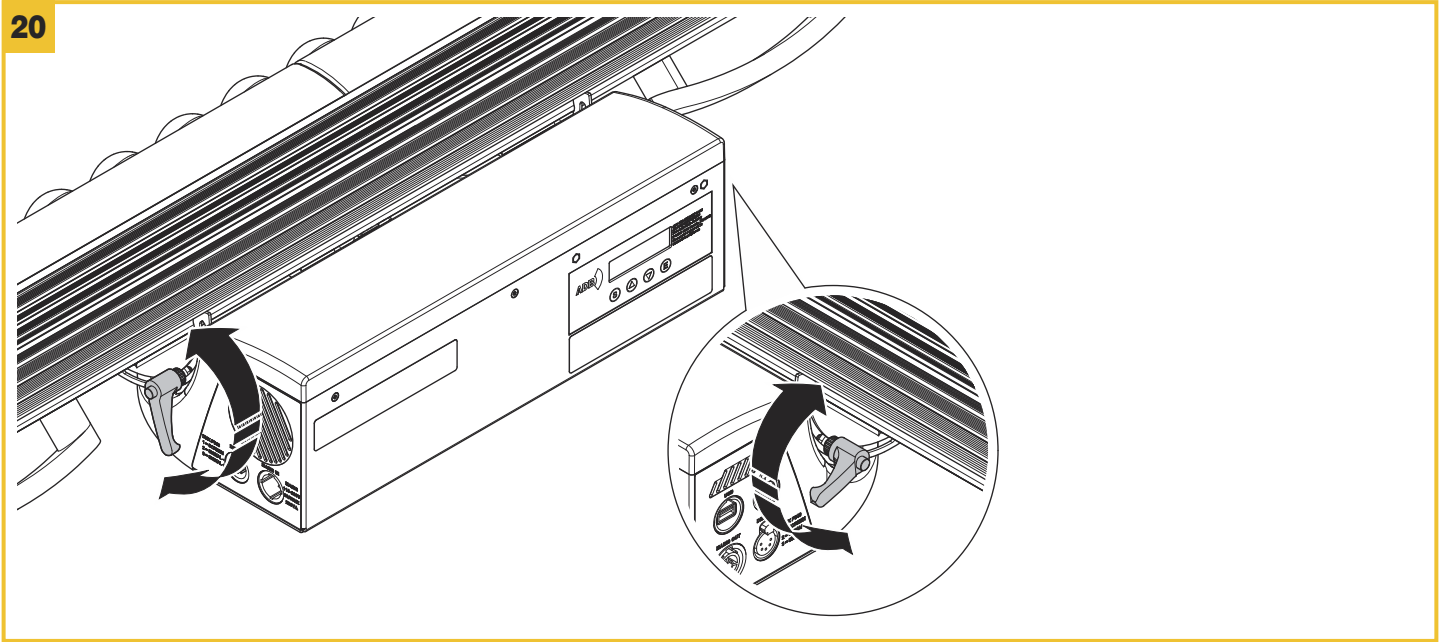

- c. Place your smartphone in the middle of the Klemantis housing as shown in the picture (**fig. 21**), so that the plastic bulges on the top surface between the lenses define the slope of your smartphone.
- d. Set the tilt angle to 43.5° to the vertical (wall) or 46.5° to the horizontal (floor) (**fig. 21-22**). The correct reference angles are shown in the layout for completeness (**fig. 23**).

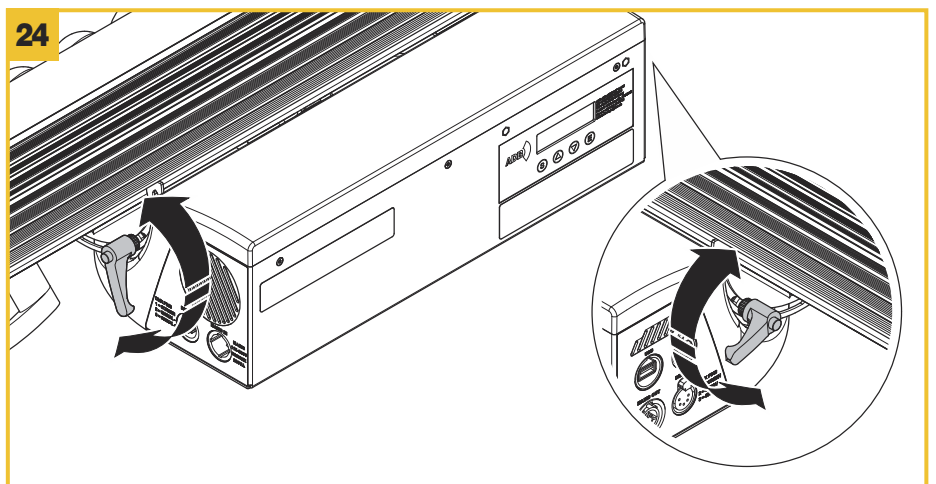
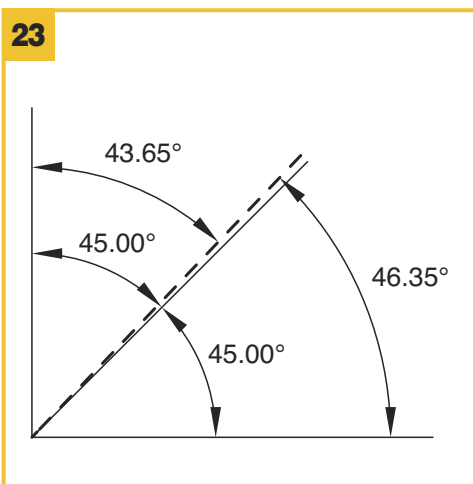
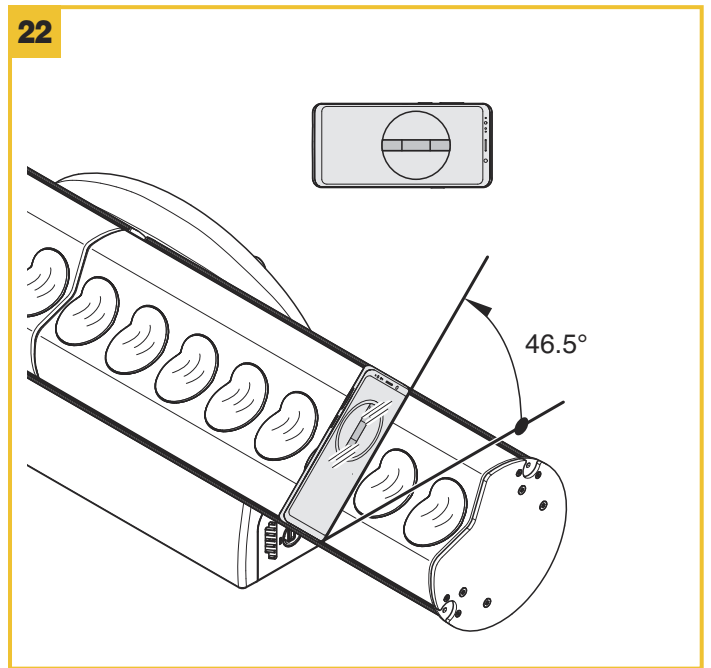
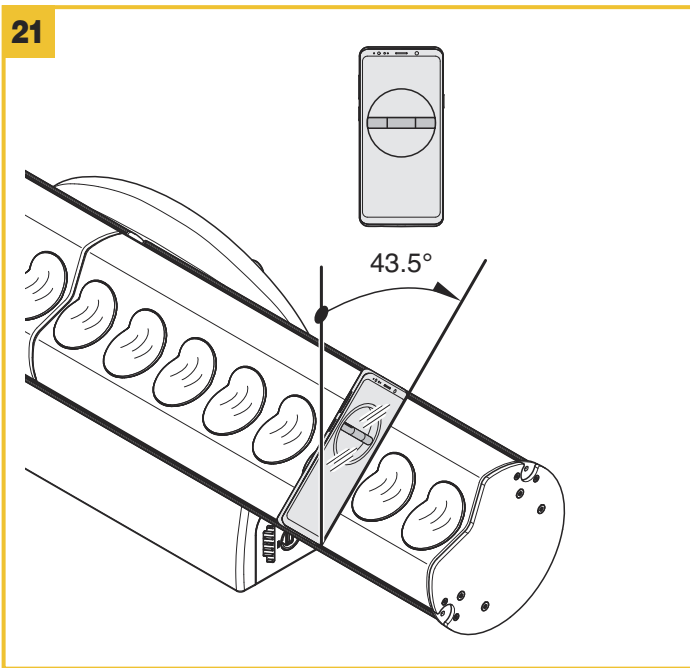

5. Turn on the bottom row of Klemantis units to illuminate the cyclorama. Observe the cyclorama from where the audience would, and single out any light peaks or gaps: these might occur at a specific Klemantis unit.
6. For each Klemantis unit identified, an observer should stand in front of the cyclorama while another person tilts the Klemantis slightly (without a digital level) to adjust its tilt finely based on feedback from the observer.
7. Tighten the tilting knobs (**fig. 24**)

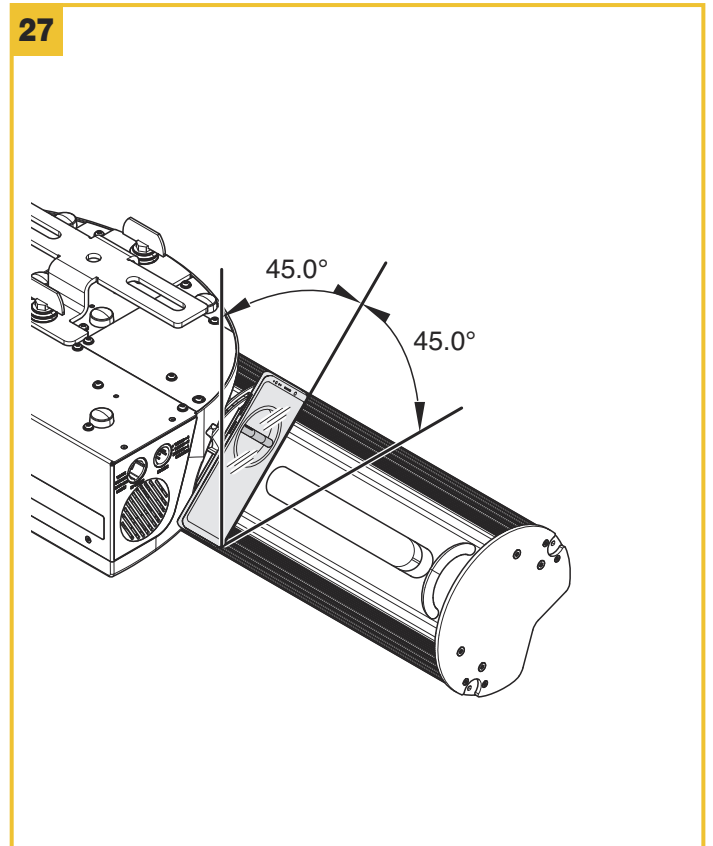
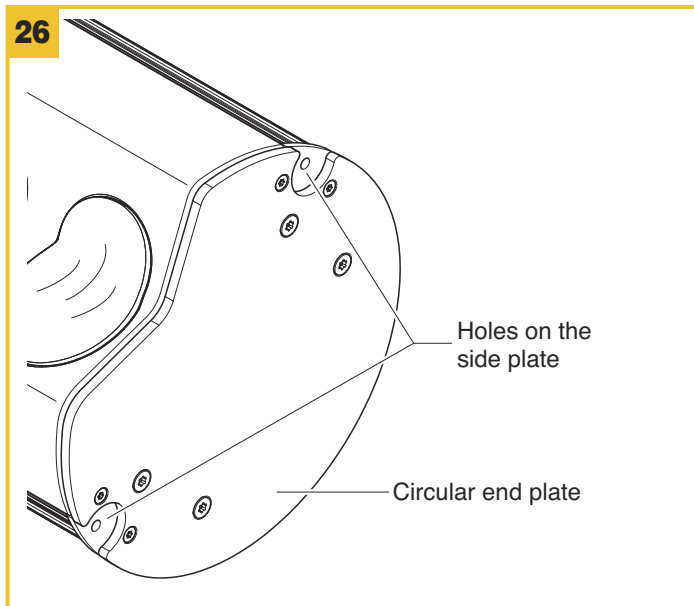
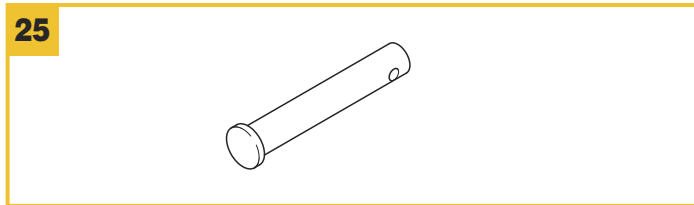

Tip: according to the observer's eye-response sensitivity and the light show, it is advisable to check the light distribution using more than one colour.
 Tip: there are two holes on the main body side plates. Use the additional clevis pins to connect two adjacent Klemantis units together and align their orientation (**fig. 25-26**).

In the case of two-row installations (floor and ceiling):

8. Repeat steps 1 to 5 for the floor units
9. Hang the top Klemantis units on a bar using the omega and straight rigid clamps provided (all identical), so they are spread out as much as possible. Make sure the bar or truss is parallel to the cyclorama, at the calculated distance (D), and reduce the gap between two adjacent fixtures to a minimum (1-2 mm).
10. Adjust all the ceiling Klemantis units in such a way that their base plates are oriented in the same way (**fig. 27**). This can be checked easily: the circular end plates on the central cylinders of the two side Klemantis units should match up (**fig. 26**).
11. Adjust the tilt of each top Klemantis unit (e.g. with a digital bubble level) (**fig. 24**):
 - a. Loosen the tilting knobs so that the Klemantis units may be tilted
 - b. Place your smartphone in the middle of the Klemantis housing as shown in the picture, so that the flat back surface of the central cylinder defines the inclination of the smartphone (**fig. 27**).
 - c. Set the tilt angle to 45°.
 - d. Tighten the tilting knobs.
 - e. Link the Klemantis units together using the clevis pins (**fig. 26**)
 - f. Raise the bar to its proper height.
12. Turn on the bottom row of Klemantis units to illuminate the cyclorama. Observe the cyclorama from where the audience would, and single out any light peaks or gaps: these might occur at a specific Klemantis unit.
13. For each Klemantis unit identified, an observer should stand in front of the cyclorama while another person tilts the Klemantis slightly (without a digital level) to adjust its tilt finely based on feedback from the observer.



I - 24068 Seriate (BG) - via Pastrengo, 3/b
Phone +39 035 654311 - www.adbstagelight.com